

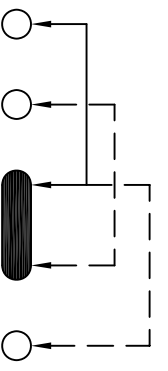

CAD FILE:

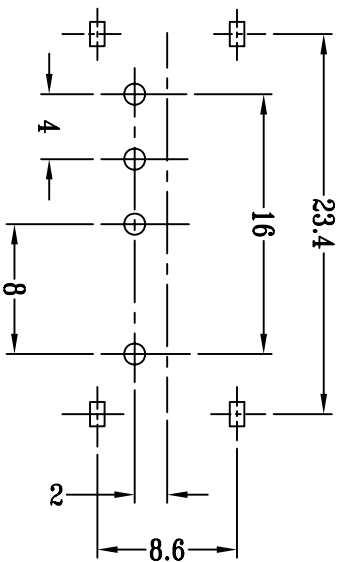
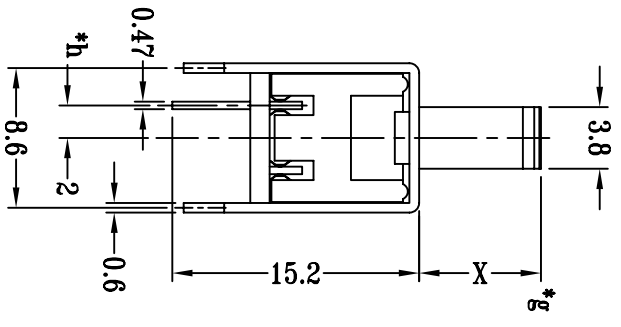
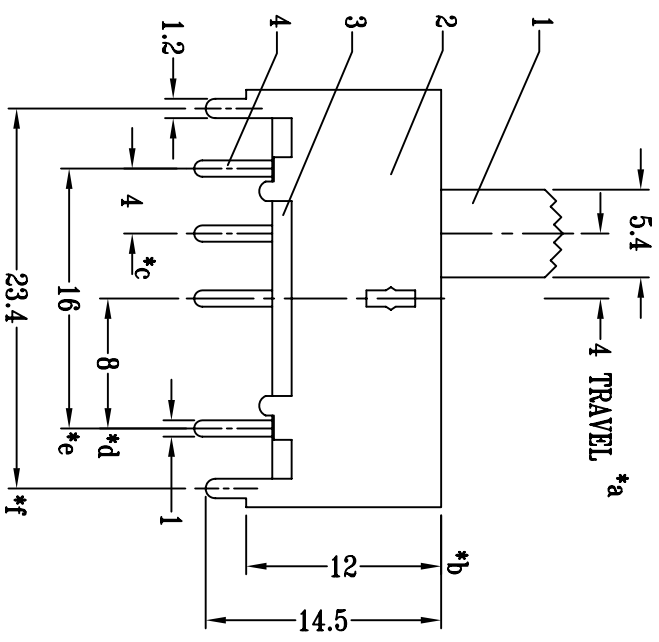
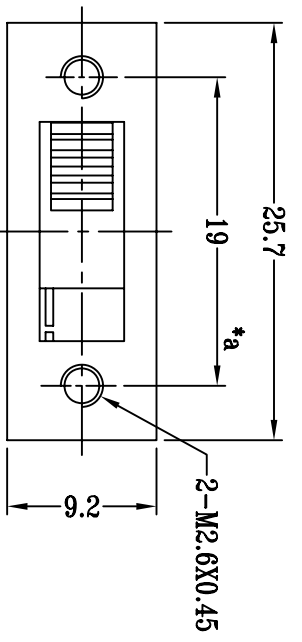

SCHEMATIC (SHORTING)

8													
7	CONTACT (CLIP)	PBS STRIP	1	Ag PLATED	TOLERANCE UNLESS SPECIFIED WITHIN: 1.5±0.1mm OVER : 1.5±0.2mm	SHENZHEN XIEJIA ELECTRONICS CO.,LTD.							
6	STEEL BALL	STEEL	2	NATURAL		ISSUE	DATE		UNIT : MM	SCALE: 2:1	DRWG NO.: XJ-DR-SS13H12-00	APPD	
5	SPRING	STEEL WIRE	1	TEMPER	TITLE: VERTICAL SLIDE SWITCH MODEL: SS-13H12						DESCRIPTIONS		APPD
4	TERMINAL	BRASS STRIP	4	Ag PLATED OVER Ni PLATED							DATE		UNIT : MM
3	TERMINAL BASE	PHENOLIC RESIN	1	BLACK	ALL MATERIALS MUST BE COMPLIANT TO ROHS						CHK'D	FANGYING	2003-4-9
2	FRAME	STEEL STRIP	1	Ni PLATED							APPD	KANGXINAN	
1	KNOB	POM	1	BLACK							APPD	KANGXINAN	2003-4-9

注：“\*”表示关键尺寸(8个)